

# INSPECTION REPORT

Manufacturer	INTERNATIONAL BRE FASTEN . LTD	
P/O No.	26-21/BRE-BFC	
Part No.	B1 #12-14x20 HWF	
Description	5.5 x 20mm, Self-drilling Screw	
Technical Diagram		

No	Inspect Item	Standard	Unit	Measured				
				1	2	3	4	5
1	Washer Diameter		mm	13.34	13.40	13.44	13.48	13.31
2	Total Head Height		mm	5.72	5.68	5.67	5.68	5.69
3	Total Length		mm	19.80	19.63	19.77	19.82	19.90
4	Major Diameter		mm	5.37	5.38	5.36	5.37	5.37
5	Pitch		mm	1.86	1.86	1.86	1.86	1.86
6	Drill Point Length		mm	8.39	8.45	8.34	8.43	8.15
7	Drill Point Width		mm	4.55	4.56	4.57	4.59	4.56
8	Torsional Strength(N.m)		N.m	11.00	11.80	10.80	11.70	11.50

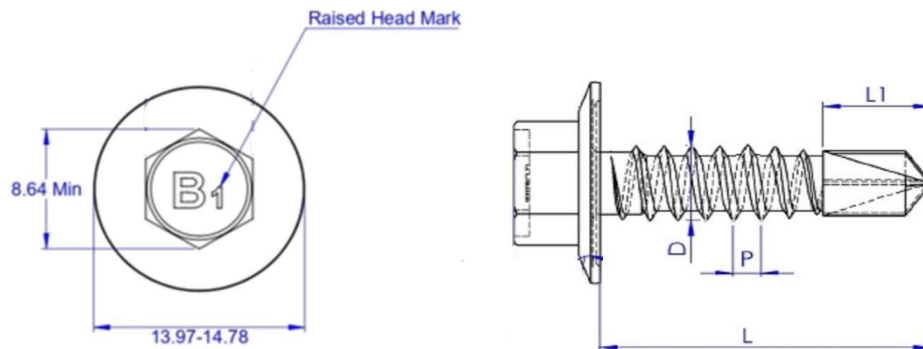

Inspection Results	<b>OK</b>	Inspected	Approved
		Date	Date